



HLO-1050 Linkage Kit

Installation Guide

CONTENTS

Introduction	1
Parts List	1
Mounting	2
Assembling	2
Calibrating	3
Tightening	3
Accessories	4
Replacement Parts	4
Related Documents	4
Important Notices	4

INTRODUCTION

Install an HLO-1050 Linkage Kit for an AFMS (Airflow Measurement System) on units with vertical-axis damper blades. The linkages transfer the damper motion to a surface with a horizontal axis, on which the AFMS controller's inclinometer can then be mounted.

Mount the kit's damper blade crankarm on a damper blade or on a jackshaft using the included jackshaft coupler and V-bolt. If unable to mount the kit's axle mount shaft to the damper frame, use a **VTD-0903** right-angle bracket (sold separately).

See the AFMS installation guide — found on any **AFMS controller's** product page — for installation of other AFMS components.

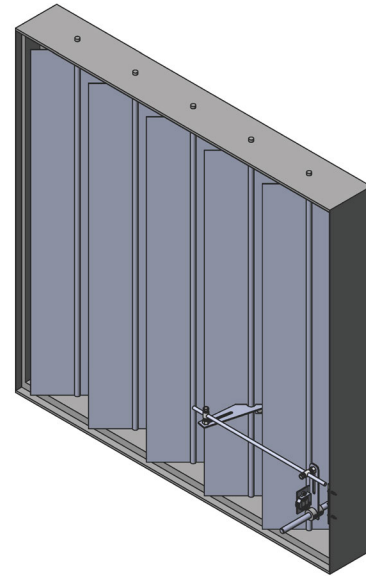

HLO-1050 — damper blade installation

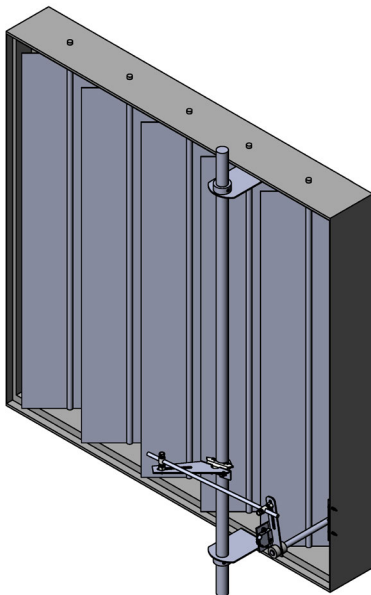

HLO-1050 — jackshaft installation

PARTS LIST

Det.	Qty.	Description
1	1	HLO-1021 : crankarm; damper blade, 6"
2	2	screw; ¼"-28 x ¾" hex head
3	2	screw; ¼"-28 x 1-¼" hex head
4	2	¼"-28 hex lock nut
5	2	VTD-0804 : ball joint, ¼"-20
6	1	HLO-1022 : drive shaft; 5/16 dia. x 16"
7	1	axle mount shaft; inclinometer
8	2	#10-32 x ¾" TEK screw
9	1	crankarm; inclinometer
10	4	screw, 8-32 x ½" Phillips pan head
11	4	#8-32 hex nut, locking
12	2	HLO-1016 : shaft retainer assembly
13	1	bearing; thrust washer ½" ID
14	1	bearing; flanged ½" ID
15	1	jackshaft coupler
16	1	V-bolt; 1"
17	1	spacer; 256 ID x .591 OD x .591

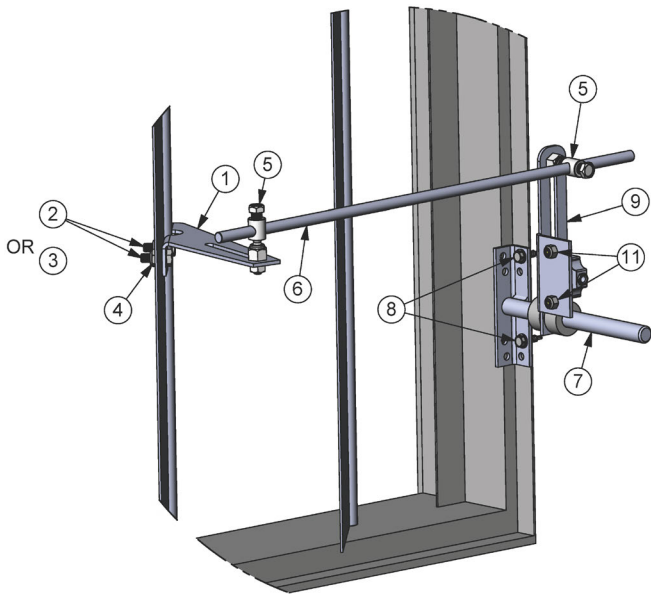

Figure A: Wide view of HLO-1050 assembly (damper blades at 45° position)

MOUNTING

1. Select a location on the damper that will allow the linkages to move freely throughout the damper blade rotation.

NOTE: Typically the **damper blade crankarm** ① mounts onto the second damper blade.

2. Fasten the **damper blade crankarm** ① to the damper blade with two **¼"-28 hex head screws** ② or ③, and two **¼"-28 lock nuts** ④. (See Figures A and B.)

NOTE: For damper blades with offset profiles, use the included **spacer** ⑬ to make the **damper blade crankarm** ① flush with the damper blade. (See Figure B.)

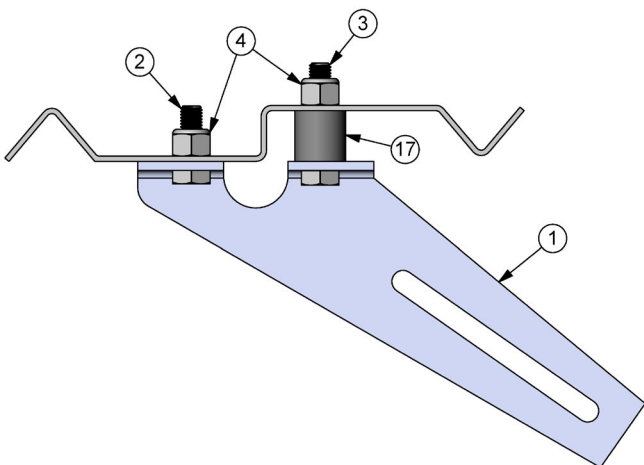

Figure B: Damper blade crankarm with spacer for a damper blade with an offset profile

NOTE: For dampers with jackshafts, use the included **jackshaft coupler** ⑮ and **V-bolt** ⑯ to fasten the crankarm to the jackshaft. (See Figure D on the next page.)

3. Rotate the damper blades to the 45° position.
4. If possible, temporarily attach the **axle mount shaft** ⑦ to the damper frame using a vise grip or clamp to allow for adjustments.

ASSEMBLING

1. Place the **inclinometer crankarm** ⑨ onto the **axle mount shaft** ⑦ using the **shaft retainer assemblies** ⑫, the **thrust washer bearing** ⑬ and the **flanged bearing** ⑭. (See Figure C.)
2. Loosely fasten the **ball joints** ⑤ to the **inclinometer crankarm** ⑨, the **damper blade crankarm** ① and the **drive shaft** ⑥. (See Figures A and C.)

NOTE: With damper blades at the 45° position, the **inclinometer crankarm** ⑨ should be vertical and positioned on the **axle mount shaft** ⑦ so that the **drive shaft** ⑥ is level and parallel with the face of the damper frame. (See Figs. A and C.)

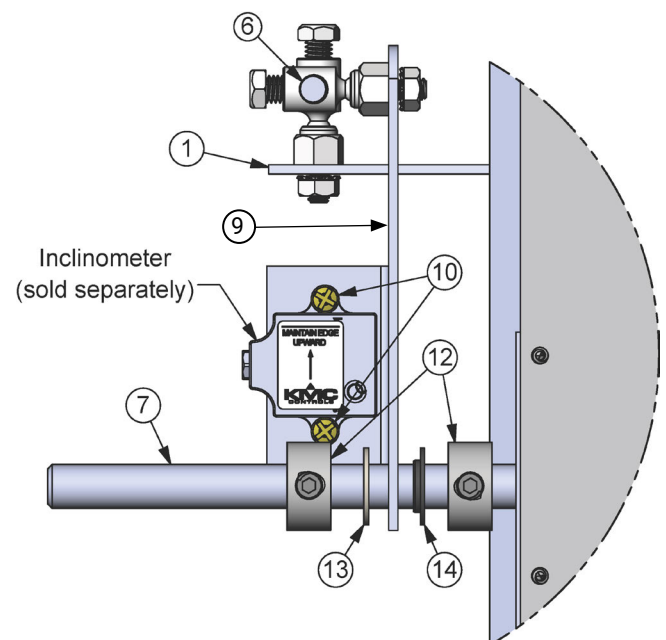

Figure C: Close view of HLO-1050 assembly (damper blades at 45° position)

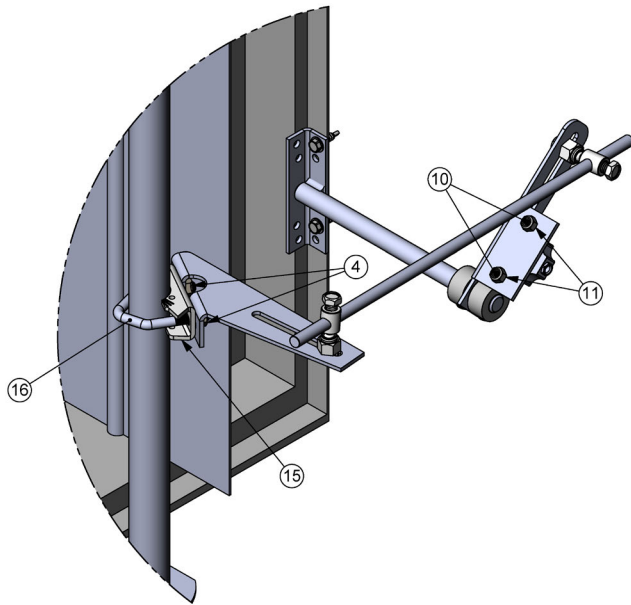

Figure D: HLO-1050 mounted using jackshaft coupler (damper fully open)

CALIBRATING

Calibration of the system for optimal performance is necessary. Keep in mind that the target range of motion for the **inclinometer crankarm** (9) is 90° when moving the damper from fully open to fully closed. (See Figure E.)

1. Open and close the damper fully to test the linkage kit's range of motion.

NOTE: With the damper at 45° the **inclinometer crankarm** (9) should be vertical (as shown in Figure A) and should travel roughly the same amount of degrees when opening and closing (per Figure E).

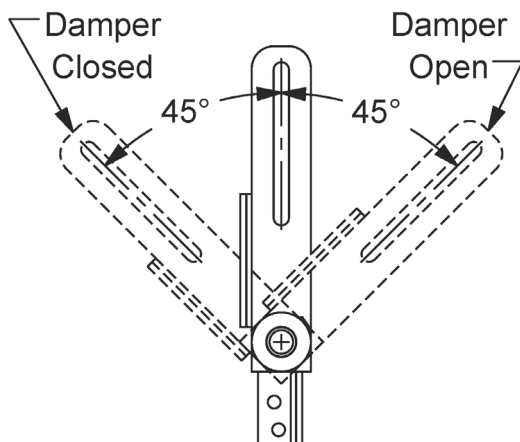

Figure E: Inclinometer crankarm target range of motion

2. Loosen clamp and adjust position if necessary.

NOTE: For optimal results, the **axle mount shaft** (7) should be positioned so that the **drive shaft** (6) is horizontal when the damper blades are at the 45° position.

3. Adjust the two **ball joints** (5) along each slot in either crankarm as needed to increase or decrease the linkage kit's range of motion.
4. If binding occurs when opening or closing the damper, adjust the distance between the **ball joints** (5) along the **drive shaft** (6).
5. If the **drive shaft** (6) collides with any one of the damper blades, move the **inclinometer crankarm** (9) along the **axle mount shaft** (7) to increase blade clearance.

NOTE: Moving the **ball joint** (5) along the slot in the **damper blade crankarm** (1) can help this process as well.

6. Repeat steps 1 to 5 as needed.

TIGHTENING

Once calibration is complete:

1. Fasten the **axle mount shaft** (7) to the damper frame with two **#10-32 TEK screws** (8).

NOTE: If unable to mount the **axle mount shaft** (7) to the damper frame (because of mounting inside a duct), use a **VTD-0903 right-angle bracket (sold separately)** and the screws shown in Figures F and G on the next page.

2. Tighten the fasteners on the **ball joints** (5) and the **shaft retainer assemblies** (12).

NOTE: The **shaft retainer assemblies** (12) must be placed tightly against the **inclinometer crankarm** (9) to prevent side-to-side play.

3. Fasten the inclinometer (sold with controller) onto the **inclinometer crankarm** (9) with two **#8-32 Phillips pan head screws** (10) and two **#8-32 lock nuts** (11). (See Figs A and C.)

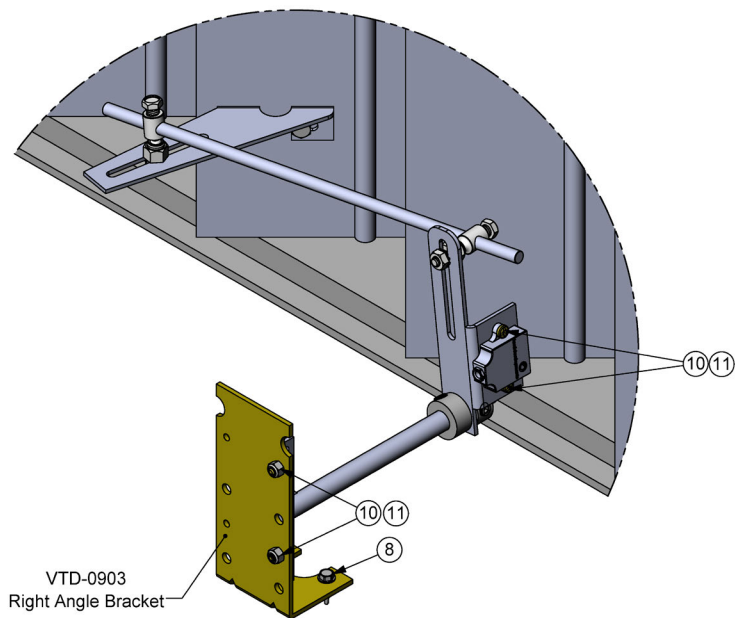

Figure F: Detail view of mounting in a duct using a VTD-0903 right-angle bracket (sold separately)

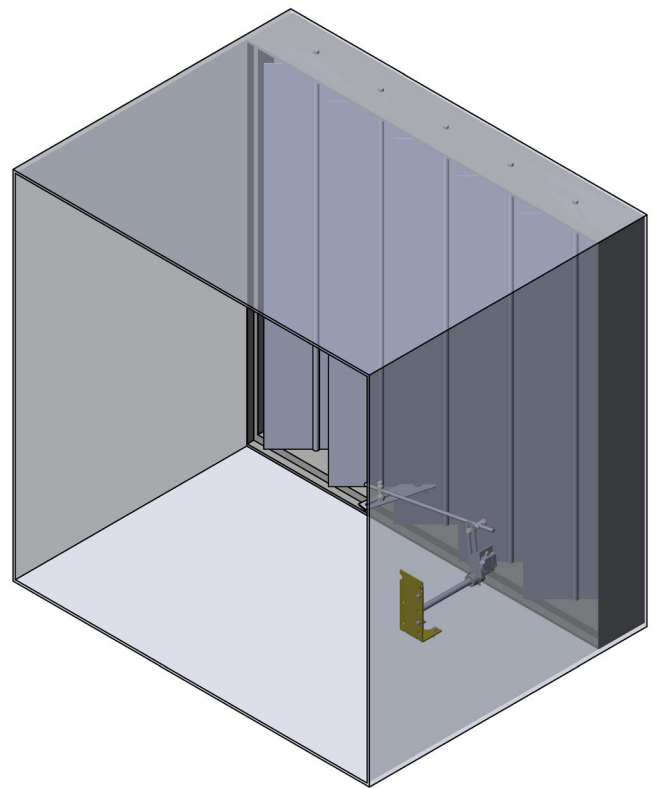

Figure G: Outside view of mounting in a duct using a VTD-0903 right-angle bracket (sold separately)

ACCESSORIES

VTD-0903 bracket, short mount, right angle

REPLACEMENT PARTS

HLO-1016 retaining collar, 1/2" shaft, pack of 20

HLO-1021 crankarm; damper blade, 6"

HLO-1022 drive shaft; 5/16 dia. x 16", pack of 5

VTD-0804 ball joint, 1/4"-20 male for side-mounted 5/16" rods, pack of 5

RELATED DOCUMENTS

Go to any **AFMS controller's** product page to find these related AFMS documents:

- *Airflow Measurement System Data Sheet*
- *Airflow Measurement System Selection Guide*
- *Airflow Measurement System Installation Guide*

IMPORTANT NOTICES

The material in this document is for information purposes only. The contents and the product it describes are subject to change without notice.

KMC Controls, Inc. makes no representations or warranties with respect to this document. In no event shall KMC Controls, Inc. be liable for any damages, direct, or incidental, arising out of or related to the use of this document.

TrueFit®, KMC Controls®, and the TrueFit logo are registered trademarks of KMC Controls, Inc. All rights reserved.

TEL: 574.831.5250

FAX: 574.831.5252

EMAIL: info@kmccontrols.com

